



Features an easy-to-use Sunday Celebration that fits into any service!

Moo-sic & More and Closing Corral



STATION LEADER MANUAL



**MOO-SIC & MORE
AND
CLOSING CORRAL**

LEADER MANUAL



LOVELAND, COLORADO
GROUP.COM

Group



Group resources really work!

This Group resource incorporates our R.E.A.L. approach to ministry. It reinforces a growing friendship with Jesus, encourages long-term learning, and results in life transformation, because it's:



Relational

Person-to-person interaction enhances spiritual growth and builds Christian friendships.

Experiential

What we experience through action and discussion sticks with us up to 9 times longer than what we simply hear or read.

Applicable

The aim of ministry is to equip people to be both hearers and doers of God's Word.

Lifelong

Experiences transform the heart, moving faith beyond the walls of church and into everyday life for years to come.

Moo-sic & More and Closing Corral Leader Manual

Copyright © 2019, 2025 Group Publishing, Inc./0000 0001 0362 4853

All rights reserved. No part of this book may be reproduced in any manner whatsoever without prior written permission from the publisher, except where noted in the text and in the case of brief quotations embodied in critical articles and reviews. For permission information, go to group.com/permissions.

Visit our websites:

group.com ✨ group.com/vbs

Thanks to the herd who rounded up this VBS! Laura Baldwin-Stout, Jody Brolsma, Stephen Caine, Shelly Dillon, Jan Kershner, Lyndsay Gerwing, Laycie McClain, Mike Porter, Joani Schultz, Rodney Stewart, and Gabriele Woolever.

Scripture quotations are taken from the *Holy Bible*, New Living Translation, copyright © 1996, 2004, 2015 by Tyndale House Foundation. Used by permission of Tyndale House Publishers, Inc., Carol Stream, Illinois 60188. All rights reserved.

ISBN 978-1-4707-7952-8

Printed in the United States of America.

10 9 8 7 6 5 4 3 2 1 27 26 25

Contents

Get Ready for a Stampede of Smiles!	4
Moo-sic & More—Day 1	9
Closing Corral—Day 1	15
Moo-sic & More—Day 2	21
Closing Corral—Day 2	27
Sunday Celebration	31
Song Lyrics & Motions	35
“Joy to the World!”	36
“All That I Am” (Psalm 103:1)	37
“Silent Night”	38
“Thankful”	39
“To God Be the Glory”	40



You Have Two Manuals in One!

Because many churches have the same person lead both the opening station and the closing, we've put all the materials in this one manual. The pages are perforated so that if you do have two separate leaders at your VBS, you can just tear out the Closing Corral section and hand it off to the Closing Corral Leader.

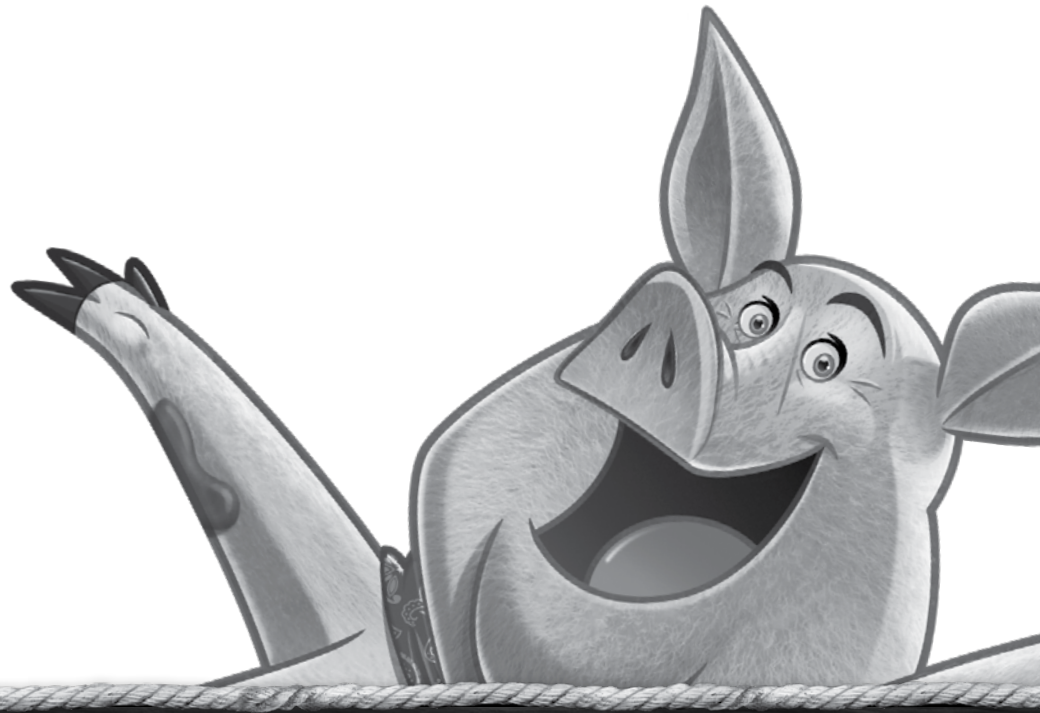

Get Ready for a Stampede of Smiles!

Saddle Up for a Wild Weekend

At Yee-Haw VBS, kids kick up their heels as they stampede through the wild frontier and celebrate the greatest truth of all—God is good! They'll round up a whole herd of friends and discover that Jesus is God's greatest gift.

Moo-sic & More is the first station kids visit each day, where they sing fun songs and discover the concepts they'll be learning. As the Moo-sic & More Leader, you'll welcome everyone, introduce the Bible Point and Bible verse, lead upbeat worship, and play a role in a silly skit with Rawhide McSpur.

Closing Corral is the last station each day, where kids and leaders all gather for lots of fun-filled, audience-involving activities that will reinforce what they've learned. As Closing Corral Leader, your job is to send kids off empowered by the fact that God gives good gifts!

HAVE YOU HERD?

Every day, you'll use an attention-getter to get everyone focused on you for more fun. A Buckaroo Bell (available from Group Publishing or your Group VBS supplier) or other attention-getter saves time and is loads better than lots of shushing or shouting.



Buckaroo Bell

- * **Everyone's on the move.** Check out the sample schedule on page 6 to get an idea of the flow of each day's activities and how Moo-sic & More and Closing Corral fit in.
- * **Everyone's in a Crew.** At Yee-Haw, kids travel in small, mixed-age groups called Crews, with up to five elementary-age kids and one adult or teenage leader. Mixed-age Crews are a fresh, incredible way to reach kids! You'll see older kids help younger ones with challenging tasks. Younger kids seek to emulate the older kids in their Crews. Preschoolers, ages 3 to 5, participate in Crews in a special preschool program. Both elementary and preschool Crews will come to Moo-sic & More and Closing Corral at the same time.
- * **Everyone has a job.** Every day, kids can choose a different Crew role. Different Station Leaders call on different roles, ensuring that everyone gets in on the fun. Crew roles include Thank You-er, Guide, Prayer Person, Materials Manager, and Schedule Supervisor.
- * **Everyone's learning one key truth.** Every activity at Yee-Haw reinforces one simple Bible truth, called a Bible Point. It's important to use the Bible Point as it's written since it's integrated into the experiences and activities throughout the entire program. Yee-Haw is intentionally designed so that some stations focus more on the key Bible verse (John 3:16) and some focus on the Bible story. However, every station connects to the Bible Point.

Kids will be listening for the Bible Point, which is **GOD GIVES GOOD GIFTS**. When kids hear the Point, they'll shout "Yee-haw!" Each time kids shout the response, they'll raise a fist in celebration.

Here's What You Need to Do

- * **Prepare your heart.** Pray for the kids who will come to Yee-Haw, for the parents, and for the other volunteers on your team. Ask God to guide and encourage your VBS Director through this exciting event.
- * **Prepare your supplies.** Work with the VBS Director to collect necessary supplies. Check with church members to see what items you can borrow.
- * **Prepare your team.** The large-group experiences flow more smoothly when you have a small team of assistants. (Middle schoolers and high schoolers make *excellent* assistants!) They might do small tasks such as hand you props, lead song motions, or help you with preparations. Be sure you have an experienced person running your sound system.
- * **Prepare your show.** Rehearse a few times with your assistants. Run through the technical side (microphones, sound system, DVD player, and projector) with your audio/visual assistant. Be familiar with your script so you can comfortably move through the activities without reading it. Be sure to use emotion, expression, and *excitement* as you lead.
- * **Prepare your wardrobe.** Wear jeans, a flannel shirt, boots, and a cowboy hat; or ask your Director what you should wear. Staff T-shirts are available from Group Publishing or your Group VBS supplier.
- * **Prepare your room.** Choose a room such as a sanctuary or fellowship hall that will comfortably seat all the participants for both the opening and closing stations. Then have fun creating a western-ranch-inspired setting that looks like a great place to horse around! You can get *fun* thematic decorations at group.com/vbs.



"Yee-haw!"



Making a Crew Sign Stand

1. Screw a $\frac{3}{4}$ -inch galvanized iron floor flange to the center of a 12-inch particle board square. Screw a $\frac{3}{4}$ to 1-inch male adapter to the flange.
2. Insert a 2-foot-long piece of 1-inch PVC into the male adapter. Paint the PVC black (optional).
3. Make two small holes near the top of the Crew sign on each side of the PVC, and run a plastic zip tie through the holes, pulling tight to fasten.

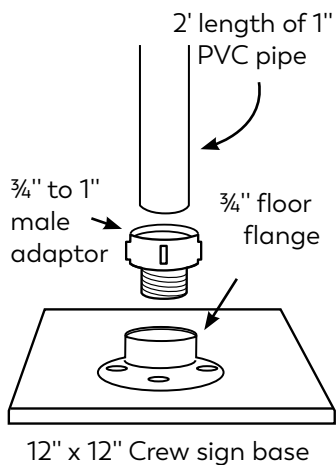

Print Crew signs from the Yee-Haw Clip Art & Resources CD, and write an identifying number or name for each Crew. Use spray adhesive to attach the signs to foam core. Tape the signs on the seating rows in your room, or make stands with PVC pipe and a square wood base. Cover the wood base with cloth bandannas, and add plastic "barbed wire" to the PVC. Or make mini hay bales by covering paper lunch sacks with yellow paper springfill, then slide them on the PVC pipe.

- * **Prepare your music.** Listen to the Moo-sic & More CD or downloads ahead of time, and use pages 36-40 in this manual, where the motions are described next to the lyrics. Be familiar with all the songs and motions so you can teach them with ease. You can also purchase the Moo-sic & More DVD to watch kids doing the actions along with onscreen lyrics. When it comes to leading the songs, you have a couple of options: Have kids sing along with the Moo-sic & More CD or DVD, or use live accompaniment with a keyboard or worship band. You can go to group.com to purchase a package of the piano sheet music for all five Yee-Haw songs. An advantage of letting children sing with the CD or DVD is that the recorded voices carry the words. Kids enjoy the beat and sounds as they sing along. So crank it up!

Time	GROUP A CREWS	GROUP B CREWS	GROUP C CREWS	Ponderosa Preschool
6:00-6:30	1-3	4-6	Moo-sic & More	7-9
<i>Allow 5 minutes to travel to your next station.</i>				
6:35-7:00	Bible Adventures	Projects-With-a-Purpose*	Saddle-Up Sports	Ponderosa Preschool
<i>Allow 5 minutes to travel to your next station.</i>				
7:05-7:30	Projects-With-a-Purpose*	Saddle-Up Sports	Bible Adventures	Ponderosa Preschool
<i>Allow 5 minutes to travel to your next station.</i>				
7:35-8:00	Saddle-Up Sports	Bible Adventures	Projects-With-a-Purpose*	Ponderosa Preschool
<i>Allow 5 minutes to travel to your next station.</i>				
8:05-8:30	Closing Corral			

Important Legal Information

When you purchase a Yee-Haw Music CD, download, or DVD, Group grants you permission to use the audio recordings, music videos, and lyrics included to conduct an in-person event/program for your church or organization.

- You do not have permission to play the songs in online services/events or to stream the music online. Email permissions@group.com or visit www.group.com for a web license.
- Unauthorized copying, public performance, and online use of the songs/videos/lyrics is prohibited by law. It is also unlawful to upload the songs/videos/lyrics, or your own recording of the song/video/lyrics, to public facing websites such as YouTube, Facebook, Vimeo, etc.
- Making your own copies of the songs/videos—even to use at your church—is against the law, which is a fact many people don't know.

Thanks for demonstrating integrity to the people you serve in how you use this ministry resource.

Day 1

Bible Point: God gives good gifts.

Bible Story: God sends Jesus to earth. (Luke 2:1-20)

Bible Verse: “For this is how God loved the world: He gave his one and only Son, so that everyone who believes in him will not perish but have eternal life.” (John 3:16)

Consider This...

- ✦ There are dozens of prophecies in the Old Testament surrounding the birth of the Messiah, and Jesus fulfills every one!
 - Jesus’ birth in Bethlehem fulfills Micah 5:2: “But you, O Bethlehem Ephrathah, are only a small village among all the people of Judah. Yet a ruler of Israel, whose origins are in the distant past, will come from you on my behalf.”
 - Jesus’ virgin birth was foretold in Isaiah 7:14: “The Lord himself will give you the sign. Look! The virgin will conceive a child! She will give birth to a son and will call him Immanuel.”
- ✦ After Jesus’ birth, Mary wrapped him in cloths and laid him in a manger. Mangers held food for animals, giving them sustenance and life. Jesus called himself the Bread of Life, and he is what gives us strength, nourishment, and everlasting life.
- ✦ The shepherds were the first people to hear the good news of Jesus’ birth. Shepherds were among the lowest of the low in their society and considered unclean. Because the angel told these men about Jesus’ birth first, God showed that his love and the gift of Jesus are for everyone.

Why It Matters...

Kids love receiving gifts—especially at Christmastime! Yet presents like bicycles and toys break. Kids outgrow new clothes, just as they grow from wanting skates to wanting smartphones. But God’s gift of Jesus is the *perfect* gift—one size fits all! As you share the Christmas story in today’s lesson, you’ll have the opportunity to help kids discover that Jesus is God’s most precious gift...for *all* of us, every day! Use today’s experiences to help kids understand *why* Jesus is a good gift, one that will be with them for eternity!

Day 2

Bible Point: God gives good gifts.

Bible Story: Jesus dies and comes back to life. (John 16–21)

Bible Verse: “For this is how God loved the world: He gave his one and only Son, so that everyone who believes in him will not perish but have eternal life.” (John 3:16)

Consider This...

- ✧ There’s interesting symbolism to Jesus carrying his own cross outside the city. In Genesis 22, Isaac carried the wood that Abraham would use to sacrifice Isaac...until God provided the ram as a sacrifice. And Leviticus 16 commands the priests to take the sin offering outside the camp or city. Jesus—the Lamb of God—became *our* sin offering!
- ✧ Roman soldiers usually crucified only non-citizens, lower-class citizens, or those accused of high treason or desertion (in wartime). The accused died a shameful, disgraceful, and agonizing death.
- ✧ Continuing the shame and disgrace of crucifixion, soldiers usually tossed the body of the crucified person into a pit. And Jesus, being penniless, didn’t have the money to pay for a formal burial. Yet Joseph of Arimathea and Nicodemus—both members of the Sanhedrin—stepped in. They took Jesus’ body and prepared it for burial themselves.
- ✧ Scholars estimate that a typical stone that was rolled over the opening of a tomb cave weighed anywhere from 1 to 3 tons!
- ✧ Although we usually think of angels with halos and wings, most times angels appear in the Bible, people describe them as looking like men. When Mary saw two angels near the tomb, she didn’t even realize they were angels!

Why It Matters...

On the surface, it may seem odd that we call Good Friday “good.” Yet without Jesus’ death, there would be no payment for sin. And there wouldn’t have been the triumphant, joyful resurrection!

Kids—and adults—find it hard to imagine *anything* good in the midst of sad times. What good can come from a loved one dying? How can a child find any good in a bully? And what’s so good about being left out or alone? God never promises that this life will be pain-free. But he *does* promise to be near when we’re hurting. What a beautiful gift! And, more important, God gave the gift of hope and joy to come. Use today’s experiences to help kids explore the eternal gift of life God gave us through Jesus.

Moo-sic & More—Day 1

Before Kids Arrive...

- * Rehearse the Rawhide McSpur skit. Rawhide is a goofy cowboy who bumbles into your station, looking for advice, friendship...and a pillow to sit on! He wears cowboy gear and might even carry a lasso.
- * Inflate 10 to 20 balloons to use for your “cattle drive.” Although any color will work, brown balloons or cow-print balloons will help kids imagine they’re herding cattle. Or just draw cow spots on white balloons.
- * Thirty minutes before Yee-Haw is scheduled to start, begin playing the Moo-sic & More CD. This will create a fun and inviting atmosphere as the kids and Crew Leaders enter your area.

Cowboy Kickoff

Say: **Hi, trailblazers! Welcome to Yee-Haw. Since we’re spending a few days in the wild west, I want to hear what you think would be the most fun thing to do on a ranch.** Tell what you’d love the most, such as learning to use a lasso, hiking trails, riding horses, or playing with all the cattle dogs. **Turn to someone sitting nearby and tell what you think would be fun to do on a ranch way out west.**

Let kids talk in pairs for about a minute. Then move into the audience with a microphone and let several kids tell what they shared.

A western ranch would be so fun—full of animals, excitement, and tons of action! That’s why I’m so wild about having you here at Yee-Haw! When people are excited about something or celebrating something good, they might shout a big, loud “Yeeeee-haw!” Lead kids in shouting their best, wildest “Yeee-haw!”

We’re celebrating God’s best gift of all—Jesus!

We’ll start each day here at Moo-sic & More. (Have fun “mooing” when you say “Moo-sic.”) **Here we’ll sing a little, talk a little, and start our day with a stampede of smiles. Everything we do at Yee-Haw will help us celebrate God’s awesome gifts. Gifts fill my heart with joy! Let’s sing “Joy to the World!” to get started.**



Lead everyone in singing “Joy to the World!” Words and motions are on page 36.

Supplies

- Bible bookmarked at John 3:16
- balloons (about 10-20)
- scissors
- Buckaroo Bell*
- Moo-sic & More Leader Version CD or download from Starter Kit
- Yee-Haw Program Resources DVD from Starter Kit
- Moo-sic & More DVD* (optional)
- media player or sound system
- DVD player and projector system
- microphone
- costume and props for Rawhide McSpur, p. 12
- photocopies of the “Who’s Who on the Crew” handout, p. 14 (1 per Crew)
- Crew bags—small tote bags or paper gift bags with handles (1 per Crew)

*available from Group Publishing or your Group VBS supplier

Moo-sic & More and Closing Corral

Get ready for a stampede of smiles!

We're so glad you joined the herd! You're in for a rip-roarin' time as you corral the entire VBS for upbeat worship that brings everyone closer to God. We've provided you with five faith-building songs that are easy to learn, fun to sing, and impossible to get out of your head. You'll also lead closing large-group activities that include surprising experiences, relationship-rich discussions, and real-life kid videos that all focus on one simple Bible truth: God gives good gifts!

This manual includes scripts, song motions, song lyrics, setup instructions, and insider tips.



Questions?



group.com/YeeHaw



Visit your Group VBS supplier



800.447.1070

Follow Group VBS on:



group.com/vbs

ISBN 978-1-4707-7952-8



9 781470 779528

VBS PROGRAMMING
Printed in the U.S.A.

Group



THIS IS A SAMPLE
The number of pages is limited.

Purchase the item for the complete version.

